

CWP FEEDS

FULL-FEATURED
FEEDING TECHNOLOGY



cooper-weymouth, peterson

FORMTEK

More Productive Metalforming Solutions

◆ A MESTEK COMPANY

ServoMax SE feeds are designed around the proven performance, accuracy and rugged reliability of ServoMax II feeds. ServoMax SE feeds now feature matte chrome rolls and provisions for mechanical stroke limiter – all as standard features. No other servo feed line packs all these features and performance at such a competitive price.



Standard Control Features:

- Slant top operator console
- Operator-friendly LCD display
- In-motion refinement of feed lengths with simple plus/minus keystroke
- Accuracy to +/- .002" roll position
- Jog feed: Jogs material to preset feed length
- Handheld remote jog station with coil cord extending to 20 ft. (4 ft. coiled) to facilitate threadup
- 500 job memory
- Metric dimensioning of feed length by simple keystroke
- Straightener interlock capability
- Tight loop interlock capability
- Auto selection of job storage
- Batch reset provided and set count and production count displayed during operation
- Batch size to 999,999
- Conforms to ANSI B-11-18 standards
- RS232 download capability

Standard Mechanical Features:

- Brushless motor technology and encoder feed back
- Precision gear drive
- Cluster gear upper roll drive
- Sealed bearings
- Pneumatic roll pressure and release
- Quick-release, cam lock edge guides
- Full width matte chrome rolls
- Entry cascade rolls
- Two-year warranty on mechanics and electronics

STANDARD DUTY FEEDS – 2.75" DIAMETER ROLLS

Model	Max. Stock Width	Capacity Full Width	Feed Length
SMXSE6	6" (152.400mm)	.187" (4.750mm)	999.999 (25.39m)
SMXSE12	12" (304.800mm)	.156" (3.962mm)	999.999 (25.39m)
SMXSE18	18" (457.200mm)	.125" (3.175mm)	999.999 (25.39m)
SMXSE24	24" (609.600mm)	.093" (2.362mm)	999.999 (25.39m)
SMXSE30	30" (762.000mm)	.078" (1.981mm)	999.999 (25.39m)
SMXSE36	36" (914.400mm)	.062" (1.575mm)	999.999 (25.39m)

Control Upgrade Options

ServoMax III

- 999 job memory
- 17% added torque

ServoMatrix

Ideal for applications requiring multiple feed lengths within a pattern

- Programmable pattern capability for up to 10 different lengths (20 lengths optional)
- Up to 99 repeats of each length in a pattern
- Six programmable outputs enable control of gaged tooling (expandable)
- Auto feed, feed length complete, repeat complete and pattern complete outputs
- Up to 150 job memory

SpeedMatic

Roll feeder motion is electronically geared to the motion of the press or shear for maximum flexibility and performance

- Auto adjust capability to match feed speed to press
- Smooth velocity profile at any press speed

ServoSensor

Ideal for applications requiring precise accuracy of a pre-printed surface

- Offers feed-to-sensor capability to a registration mark
- Accurate material positioning through precision feedback from optical sensor

ServoMax III feeds provide next-generation feeding capability from 6" to 84" width capacity. ServoMax III, two-roll and four-roll feed systems deliver enhanced features, including increased job memory and torque output for heavier capacity or increased production requirements. ServoMax III control systems can also be adapted to most existing servo driven roll feeders.



Standard Control Features:

- Slant top operator console
- Two-line, 80-character vacuum fluorescent display
- In-motion refinement of feed lengths with simple plus/minus keystroke
- Accuracy to +/- .002" roll position
- Jog feed: Jogs material to preset feed length
- Handheld remote jog station with coil cord extending to 20 ft. (4 ft. coiled) to facilitate threadup
- 999 job memory
- Metric dimensioning of feed length by simple keystroke
- Straightener interlock capability
- Tight loop interlock capability
- Auto selection of job storage
- Batch reset provided, set count and production count displayed during operation
- Batch size to 999,999
- Conforms to ANSI B-11-18 standards
- RS232 download capability

Standard Mechanical Features:

- 4:1 mechanical advantage for roll lift and down pressure
- Brushless motor technology and encoder feed back
- Precision gear drive
- Cluster gear upper roll drive
- Sealed bearings
- Pneumatic roll pressure and release
- Quick-release, cam lock edge guides
- Full width matte chrome rolls
- Entry cascade rolls
- Two-year warranty on mechanics and electronics

HIGH CAPACITY FEEDS – 4" DIAMETER ROLLS

Model	Max. Stock Width	Capacity Full Width	Feed Length
SMXIII12H	12" (304.800mm)	.250" (6.350mm)	999.999 (25.39m)
SMXIII18H	18" (457.200mm)	.187" (4.750mm)	999.999 (25.39m)
SMXIII24H	24" (609.600mm)	.187" (4.750mm)	999.999 (25.39m)
SMXIII30H	30" (762.000mm)	.156" (3.962mm)	999.999 (25.39m)
SMXIII36H	36" (914.400mm)	.125" (3.175mm)	999.999 (25.39m)
SMXIII42H	42" (1066.800mm)	.093" (2.362mm)	999.999 (25.39m)
SMXIII48H	48" (1219.200mm)	.062" (1.575mm)	999.999 (25.39m)

HEAVY DUTY FEEDS – 6" DIAMETER ROLLS

Model	Max. Stock Width	Capacity Full Width	Feed Length
SMXIII12H6	12" (304.800mm)	.375" (9.525mm)	999.999 (25.39m)
SMXIII18H6	18" (457.200mm)	.328" (8.331mm)	999.999 (25.39m)
SMXIII24H6	24" (609.600mm)	.281" (7.137mm)	999.999 (25.39m)
SMXIII30H6	30" (762.000mm)	.250" (6.350mm)	999.999 (25.39m)
SMXIII36H6	36" (914.400mm)	.203" (5.156mm)	999.999 (25.39m)
SMXIII42H6	42" (1066.800mm)	.156" (3.962mm)	999.999 (25.39m)
SMXIII48H6	48" (1219.200mm)	.125" (3.175mm)	999.999 (25.39m)
SMXIII54H6	54" (1371.600mm)	.110" (2.794mm)	999.999 (25.39m)
SMXIII60H6	60" (1524.000mm)	.093" (2.362mm)	999.999 (25.39m)

NOTE: Extra Heavy-Duty Feeds with 8" dia. rolls available (consult factory).

SMX III Control Options

ServoMatrix Ideal for applications requiring multiple feed lengths within a pattern

- Programmable pattern capability for up to 10 different lengths (20 lengths optional)
- Up to 99 repeats of each length in a pattern
- Six programmable outputs enable control of gaged tooling
- Auto feed, feed length complete, repeat complete and pattern complete outputs
- Up to 150 job memory

SpeedMatic Roll feeder motion is electronically geared to the motion of the press or shear for maximum flexibility and performance

- Auto adjust capability to match feed speed to press
- Smooth velocity profile at any press speed

ServoSensor Ideal for applications requiring precise accuracy of a pre-printed surface

- Offers feed-to-sensor capability to a registration mark
- Accurate material positioning through precision feedback from optical sensor

The 4-roll feed design permits unparalleled traction by providing twice the surface area to maintain superior contact with the material. In addition, its exclusive backed-up roll system prevents roll deflection while ensuring proper parallelism. This unique design allows the user to process critical finish products more effectively with one-half the roll pressure.



Standard Control Features:

- Slant top operator console
- Two-line, 80-character vacuum fluorescent display
- In-motion refinement of feed lengths with simple plus/minus keystroke
- Accuracy to +/- .002" roll position
- Jog feed: Jogs material to preset feed length
- Handheld remote jog station with coil cord extending to 20 ft. (4 ft. coiled) to facilitate threadup
- 999 job memory
- Metric dimensioning of feed length by simple keystroke
- Straightener interlock capability
- Tight loop interlock capability
- Auto selection of job storage
- Batch reset provided and set count and production count displayed during operation
- Batch size to 999,999
- Conforms to ANSI B-11-18 standards
- RS232 download capability

Standard Mechanical Features:

- Brushless motor technology and encoder feed back
- Backed up rolls
- Precision oil bath gear box
- All four rolls driven
- Sealed bearings
- Pneumatic roll pressure and release
- Quick-release, cam lock edge guides
- Full width matte chrome rolls
- Entry cascade rolls
- Two-year warranty on mechanics and electronics

*Multi-function
ServoMax III
Control*



4-ROLL FEEDS – 4" DIAMETER ROLLS (Backed up)

Model	Max. Stock Width	Capacity Full Width	Feed Length
SMXIII12SE4	12" (304.800mm)	.250" (6.350mm)	999.999 (25.39m)
SMXIII18SE4	18" (457.200mm)	.250" (6.350mm)	999.999 (25.39m)
SMXIII24SE4	24" (609.600mm)	.219" (5.560mm)	999.999 (25.39m)
SMXIII30SE4	30" (762.000mm)	.219" (5.560mm)	999.999 (25.39m)
SMXIII36SE4	36" (914.400mm)	.187" (4.750mm)	999.999 (25.39m)
SMXIII42SE4	42" (1066.800mm)	.187" (4.750mm)	999.999 (25.39m)
SMXIII48SE4	48" (1219.200mm)	.187" (4.750mm)	999.999 (25.39m)
SMXIII60SE4	60" (1524.000mm)	.187" (4.750mm)	999.999 (25.39m)
SMXIII72SE4	72" (1828.800mm)	.156" (3.962mm)	999.999 (25.39m)
SMXIII84SE4	84" (2133.600mm)	.156" (3.962mm)	999.999 (25.39m)

NOTE: Heavy-duty 6" diameter 4-roll feeds available. Consult factory.

CWP SERVO FEED FLEXIBILITY



Straightener/Feeder

The straightener-feeder configuration is ideal for difficult jobs that require a higher degree of straightening and requires approximately one-third less floor space than a conventional line equipped with an independent servo feed and straightener. CWP straightener-feeders are equipped with entrance and exit feed rolls with a precision straightener mounted in between. The entrance feed rolls thread the material in the machine, and then assist the exit feed rolls in accurately positioning the material. The straightener-feeder provides twice as much grip force as the servo pull-through straightener combination. Depending on application needs, all of the straightening rolls can be powered, reducing material slippage and ensuring accurate part length.



Zig-Zag Feeds

CWP zig-zag servo feed configurations offer dramatic productivity advantages in stagger feeding. Zig-zag feed controls are operator friendly and automatically calculate and set up all machine parameters quickly and accurately. CWP zig-zag feeds provide fast, easy set-up in dual axis format. The control automatically calculates the optimum movement in each axis and the feed simultaneously delivers the material in X-Y movement.

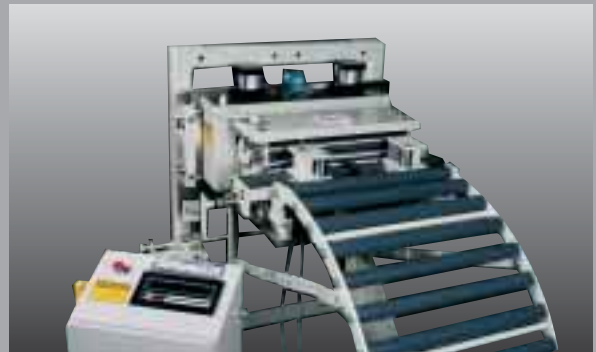

Feed/Pull-Through Straightener

The servo feed/pull-through straightener configuration provides a cost-effective and space-saving solution for a variety of coil processing applications. CWP feed/pull-through straighteners provide maximum pulling power and gripping force to position the material precisely to length at required production rates while also providing the power to straighten the material.



Push/Pull Servo System

Designed to be used in applications where long feed lengths with thin material are being processed. The exit unit can be adjusted to have a slightly greater feed length than the entry unit to keep material from binding within the tooling. Also ideal for applications where it is necessary to remove and clear a small skeleton from the tooling.

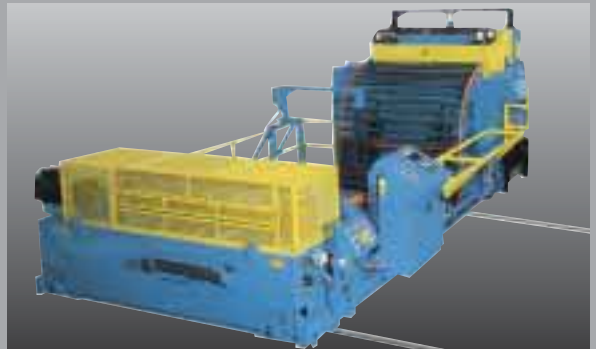

Traveling Servo Feeds

Designed to be used in conjunction with transfer press applications. When the servofeed is not processing coil fed applications it is designed to unclamp from the press and power travel away from press either to the side or straight back toward the straightener. This allows for the storage cart to be placed in position to blank feed the transfer applications within the press.

CWP SERVO FEED OPTIONS



Adjustable Mounting Bracket
 (2) piece bracket design with a jack screw arrangement for up to 3" of passline height adjustment. Allows for the feed to be mounted directly to the press.



Step-Down Transformer
 to provide (3) phase power from 440 V through 480 V and to protect the control against power spikes.



Adjustable Cabinet Base
 A rugged steel weldment cabinet is furnished to a customer-specified passline height suited to the application. Passline height adjustment is provided via a handcrank for up to 8" of adjustment.



Touch-Screen Control
 provides increased job memory and feed capabilities, in addition to programmability, for automatic setup of the entire feed system, called up by job number.



Adjustable Floor Stand
 The unique gib-guided, self-leveling design allows for quick and accurate passline height adjustment of up to 6" and allows the stand to hold its position once set, eliminating the need to secure the feed to the press.



Automatic Central Lubrication
 with an air pump and electric timer, facilitates maintenance by ensuring properly metered lubrication to all critical points.



Handwheel Adjusted Self-Centering Edge Guides
 provide superior adjustable edge guidance control for varying stock widths from a single point of adjustment. Guides incorporate a slip-gear arrangement to allow off-center operation where required.

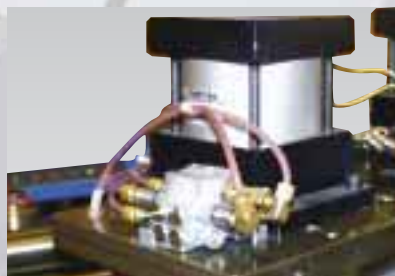

Single-Point Lubrication
 all critical lubrication points are plumbed to a common manifold with a single grease fitting for ease of maintenance.



Anti-Backup Roll Assembly
 to prevent the pull-back of stock during feed roll release (pilot lift). As an added safety feature, the anti-backup rolls will also hold the material during a loss of power.



Powered Height Adjustment w/Pneumatic Press Clamp
 to raise and lower the passline height from the operator's station via push-button control with a pneumatic clamping device to lock the feed cabinet securely to the press.

Additional Options:

- High Speed Pneumatic Roll Lift
- High Speed Software Package
- Dual Regulator Pneumatic System
- Telescoping Stock Support Assembly
- Stock Lubricators
- Polyurethane & Smooth Chrome Roll Packages
- Air Cylinder Spacers for Increased Feed Roll Opening
- Spring Kit to Modify Roll Lift for Thin Materials
- Spanish Language Keypad
- Additional Custom Options: Consult Factory

GENERAL INFORMATION

SMX SE Dimensional Drawings

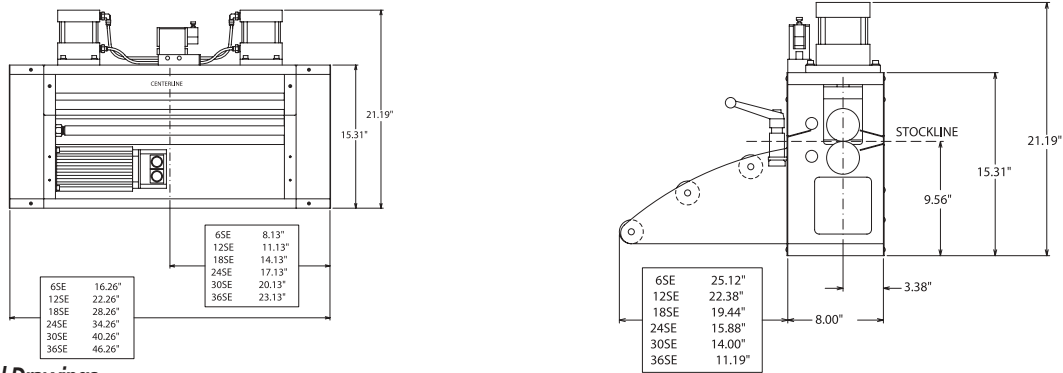

SMXIII H Dimensional Drawings

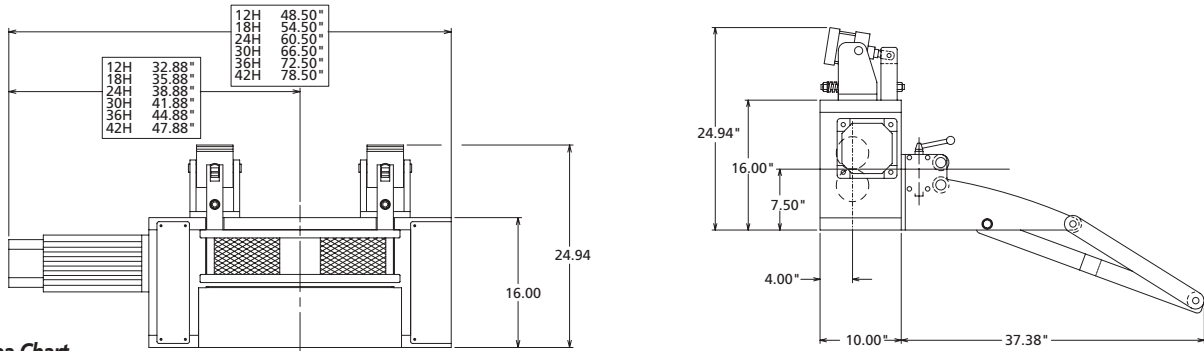

Looping Area Chart

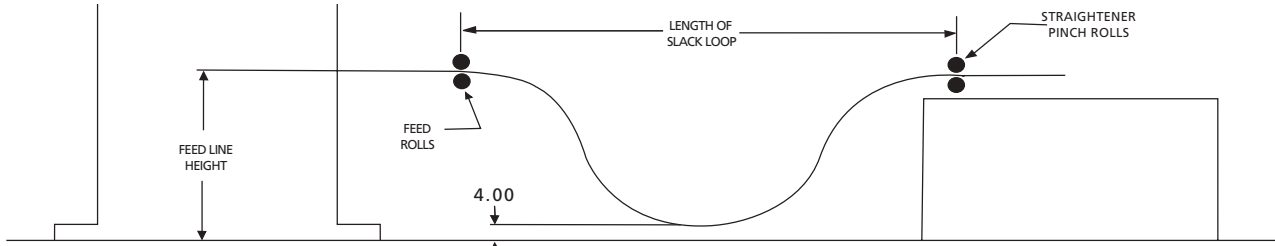

Stock Thickness mild steel (45 k psi yield)	Passline Height (Depth of Loop)															
	42"	44"	46"	48"	50"	52"	54"	56"	58"	60"	62"	64"	66"	68"	70"	
	Maximum Material Available in Loop (inches) Length of Slack Loop (inches)															
.062"	max. mat'l in slack loop	38.50	42.00	45.50	49.50	53.50	57.50	61.50	65.50	69.50	73.50	77.50	81.50	85.50	89.50	93.50
	length of slack loop	88.31	88.80	89.12	89.25	89.25	89.25	89.25	89.25	89.25	89.25	89.25	89.25	89.25	89.25	89.25
.080"	max. mat'l in slack loop	32.50	35.00	38.00	41.00	44.00	48.00	51.50	55.00	58.50	62.50	66.50	70.50	74.50	78.50	82.50
	length of slack loop	108.31	109.69	110.88	111.94	112.81	113.62	114.19	114.65	115.00	115.19	115.19	115.19	115.19	115.19	115.19
.100"	max. mat'l in slack loop	28.00	30.50	33.00	36.00	38.50	41.50	44.00	47.00	50.00	53.00	56.50	60.00	63.00	67.00	70.50
	length of slack loop	126.94	129.00	130.88	132.66	134.25	135.75	137.12	138.31	139.44	140.38	141.25	142.00	142.62	143.12	143.50
.125"	max. mat'l in slack loop	25.00	27.00	29.00	31.00	33.50	36.00	38.50	41.00	43.50	46.00	49.00	51.50	54.50	57.50	60.50
	length of slack loop	146.88	149.69	152.25	154.69	157.00	159.19	161.25	163.19	165.00	166.69	168.25	169.69	171.06	173.31	173.50
.156"	max. mat'l in slack loop	22.00	23.50	25.50	27.50	29.50	31.50	33.50	35.50	38.00	40.50	42.00	45.00	47.50	50.00	52.50
	length of slack loop	168.44	171.88	175.19	178.31	181.31	184.19	186.88	189.54	192.00	194.38	196.62	198.75	200.81	202.75	204.69
.187"	max. mat'l in slack loop	20.00	21.50	23.00	25.00	26.50	28.50	30.50	32.50	34.50	36.50	38.50	40.50	42.50	44.50	47.00
	length of slack loop	187.50	191.50	195.38	199.12	202.69	206.12	209.38	212.56	215.62	218.56	221.38	224.12	226.75	229.25	231.62
.200"	max. mat'l in slack loop	19.00	20.50	22.50	24.00	25.50	27.50	29.00	31.00	33.00	35.00	37.00	39.00	41.00	43.00	45.00
	length of slack loop	194.94	199.19	203.31	207.25	211.00	214.69	218.19	221.56	224.81	228.00	231.00	233.94	236.75	239.50	242.12
.250"	max. mat'l in slack loop	17.00	18.00	20.00	21.00	22.50	24.00	26.00	27.50	29.00	31.00	32.50	34.00	36.00	38.00	40.00
	length of slack loop	221.25	226.25	231.12	235.81	240.38	244.75	249.00	253.12	257.12	260.94	264.69	268.31	271.88	275.25	278.69
.312"	max. mat'l in slack loop	15.00	16.00	17.50	19.00	20.00	21.50	23.00	24.50	26.00	27.50	29.00	30.50	32.00	33.50	35.00
	length of slack loop	250.00	255.88	261.62	267.06	272.38	277.56	282.62	287.50	292.19	296.81	301.31	305.69	309.88	314.06	218.12
.500"	max. mat'l in slack loop	11.50	12.50	13.50	14.50	16.00	17.00	18.00	19.00	20.00	21.50	22.50	23.50	24.50	26.00	27.00
	length of slack loop	322.00	329.88	337.50	344.94	352.19	359.19	366.06	372.75	379.25	385.69	391.88	398.00	404.00	409.81	415.50



**Feeding today's stamping operations
with tomorrow's technology**

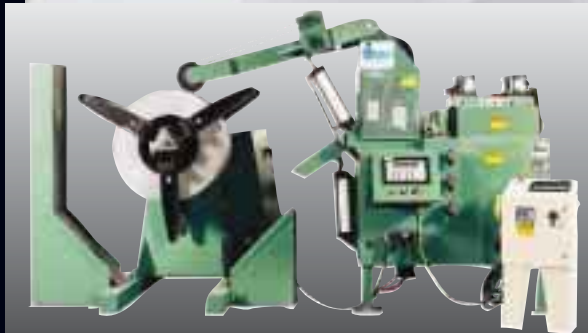

12" wide x .250" thick x 10,000 lb. press feeding system featuring space-saving ServoMax Straightener/Feeder.

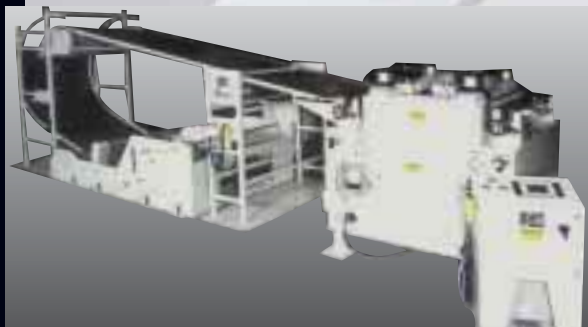

42" wide x .125" thick x 10,000 lb. press feeding system featuring a high capacity ServoMax straightener/feeder unit with 12 digit alpha numeric touch screen control.

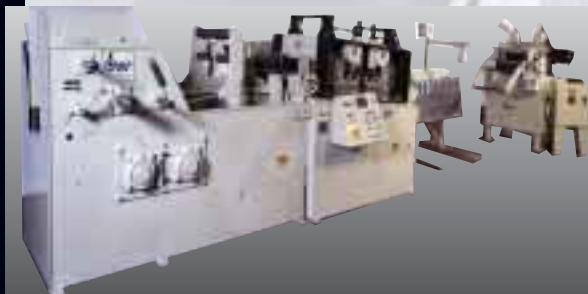

18" wide x .375" thick x 20,000 lb. press feeding system featuring combination Cradle Straightener with coil catcher, peeler and decurler, and heavy-duty ServoMax feed.

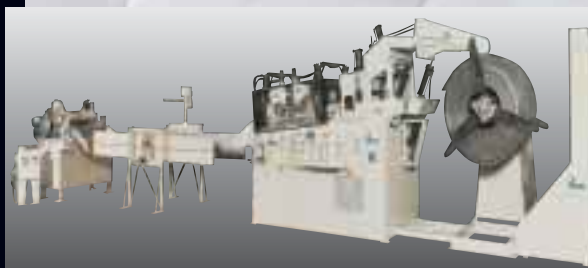

36" wide x .250" thick x 20,000 lb. press feeding system featuring high-capacity ServoMax feed.



Cut-To-Length Systems
48" wide x .200" thick x 30,000 lb. Cut-to Length system featuring a high capacity 4-roll ServoMax III feed unit. This unit is ideal for CTL applications providing twice the contact area with half the roll pressure which transmits into more accurate blanks.

cooper-weymouth, peterson
Hinckley Road, Clinton, Maine 04927
(207) 426-2351 FAX: (207) 426-8868
Toll-Free 1-800-247-COIL
www.cwcoil.com

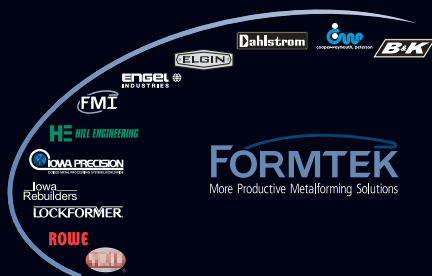

FORMTEK
More Productive Metalforming Solutions

www.formtekinc.com

◆ A MESTEK COMPANY